

DIRECTORY:

FITTING POSITIONS SHOWN ARE STANDARD. PLEASE INDICATE WITH DIMENSIONS IF REQUIRED IN A DIFFERENT LOCATION. TANK SHOWN IS SUITABLE FOR SCREW TYPE SENDER UNIT (WITH PICKUP / RETURN PIPES SEPARATE FROM SENDER UNIT).

SCREW TYPE SENDER UNIT MOUNTING PLATE
Sender Plate is supplied blank and will need to be drilled and tapped by customer unless sender is supplied for fitment

ISSUE	DETAILS	DATE
A	TO BE APPROVED FOR MANUFACTURE	

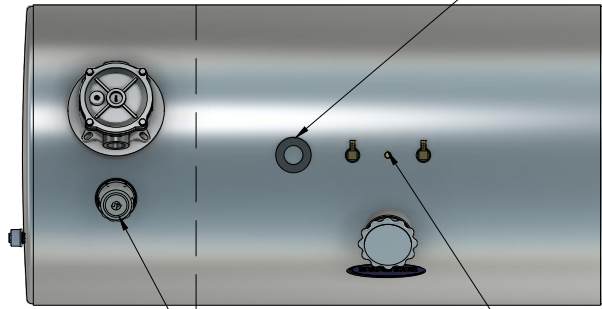

CHROME FILLER/BREATHER

BRASS FUEL TANK BREATHER

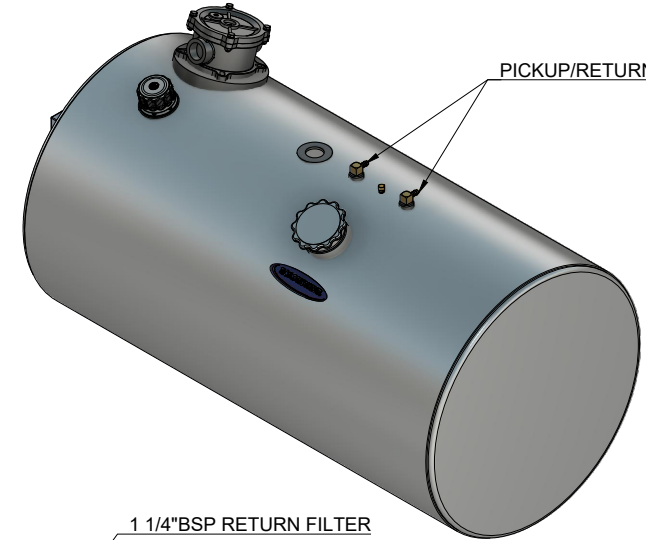

PICKUP/RETURN PIPES

LEVEL/TEMP GAUGE

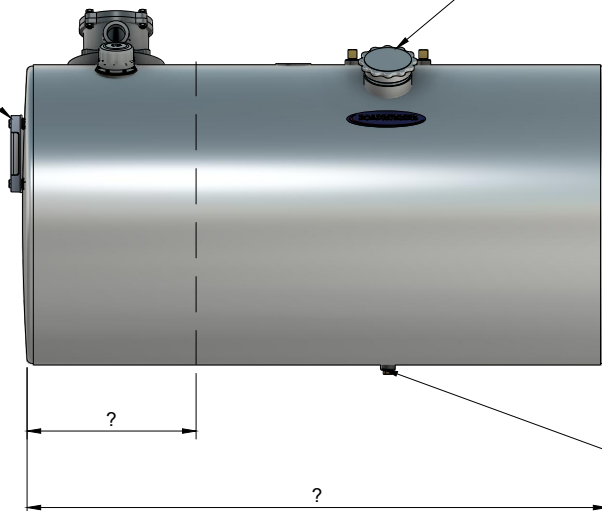

NON-LOCKING ROADRUNNER FUEL CAP

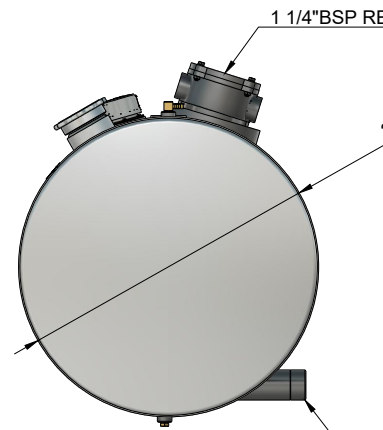

1 1/4" BSP RETURN FILTER

1 1/4" BSP SUCTION PORT

3/8" BSP DRAIN AND BUNG

TANK DIAMETER	
Ø 380	
Ø 460	
Ø 570	
Ø 635	
Ø 660	
Ø 710	

THIS DRAWING AND/OR ELECTRONIC MEDIA CONTAINING THIS DRAWING REMAIN THE PROPERTY OF ROADRUNNER MANUFACTURING LTD. IT MAY NOT BE COPIED OR USED IN ANY UNORTHERISED MANNER

ROADRUNNER
ROADRUNNER MANUFACTURING (NZ) LIMITED



CLIENT:

TITLE: Round Combo Tank Specs - Screw Type Sender

DATE:

SCALE: 1:16

DRAWN BY: Steve Tunncliffe

PRODUCT CODE:

JOB NUMBER

SHEET:

1/1

ISSUE: